

SCHALKASTEN
CONTROL CABINET
ARMOIRE DE COMMANDE

EXTRUDERKOPF
EXTRUDER HEAD
TETE D'EXTRUSION

RINGSIGNATOR RS 70
BAND MARKER RS 70
MARQUEUR PAR ANNEAUX RS 70

WASSERBAD
COOLING TROUGH
BAIN D'EAU

FREQUENZGEBER
FREQUENZY GENERATOR
CAPTEUR DE FREQUENCE

STS RS 10001 (9306)

FG8809

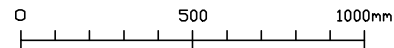
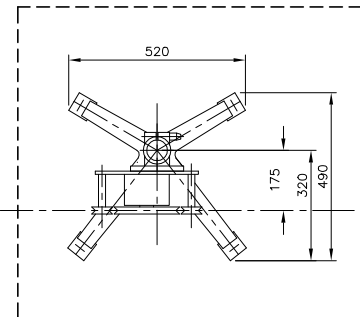
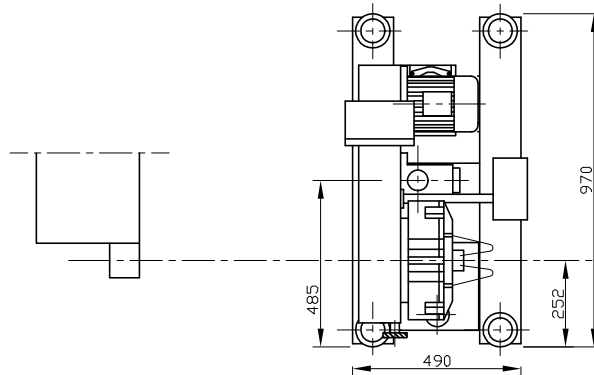
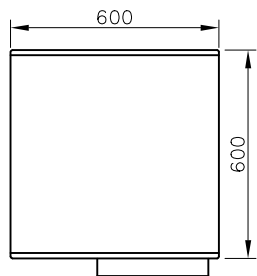
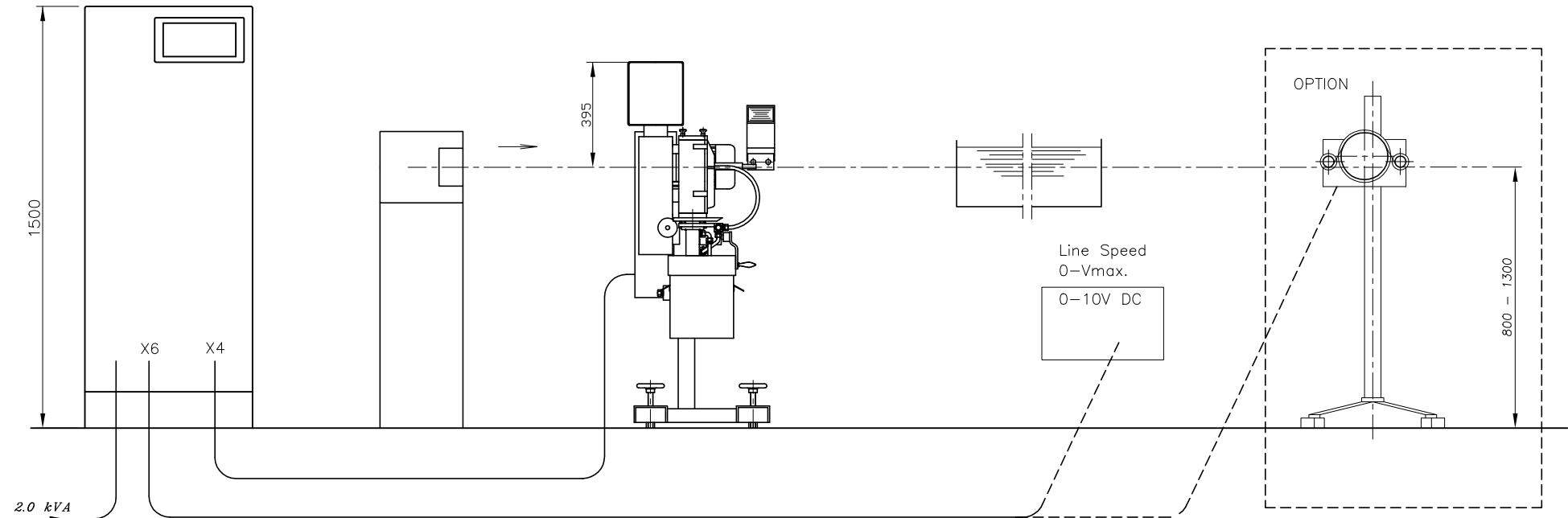

Freimasstoleranz nach ÖNORM M 1365 - Genauigkeitsgrad >FEIN 1<

Benennung
Setting up of the complete
Ring Marking Equipment
Model RS 70

MEDEK & SCHÖRNER
Gesellschaft m. b. H.
Präzisionsmechanik - Maschinenbau - Elektronik
A - 1142 Wien Kuefsteingasse 32 Austria

gezeichnet 96.04.19 Maier P.
Cueiltigkeit

Gerät
RS 70

Z. Nr.
AZ Nr. 1209