

SCHALKASTEN
CONTROL CABINET
ARMOIRE DE COMMANDE

EXTRUDERKOPF
EXTRUDER HEAD
TETE D'EXTRUSION

RINGSIGNATOR 2xRS70
BAND MARKER 2xRS70
MARQUEUR PAR ANNEAUX 2xRS70

WASSERBAD
COOLING TROUGH
BAIN D'EAU

FREQUENZGEBER
FREQUENZY GENERATOR
CAPTEUR DE FREQUENCE

STS RS 10001 (9306)

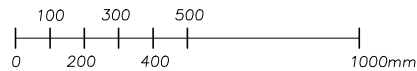
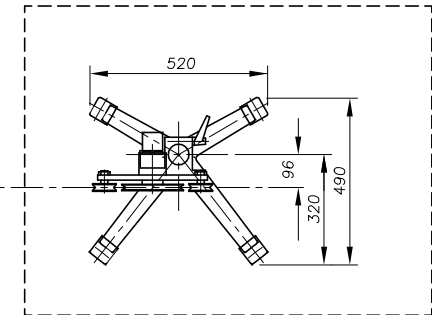
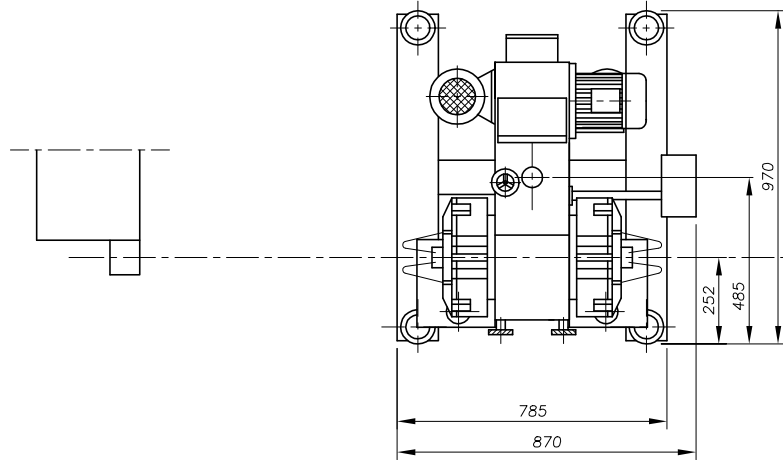
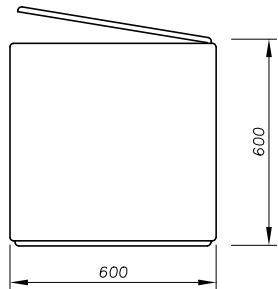
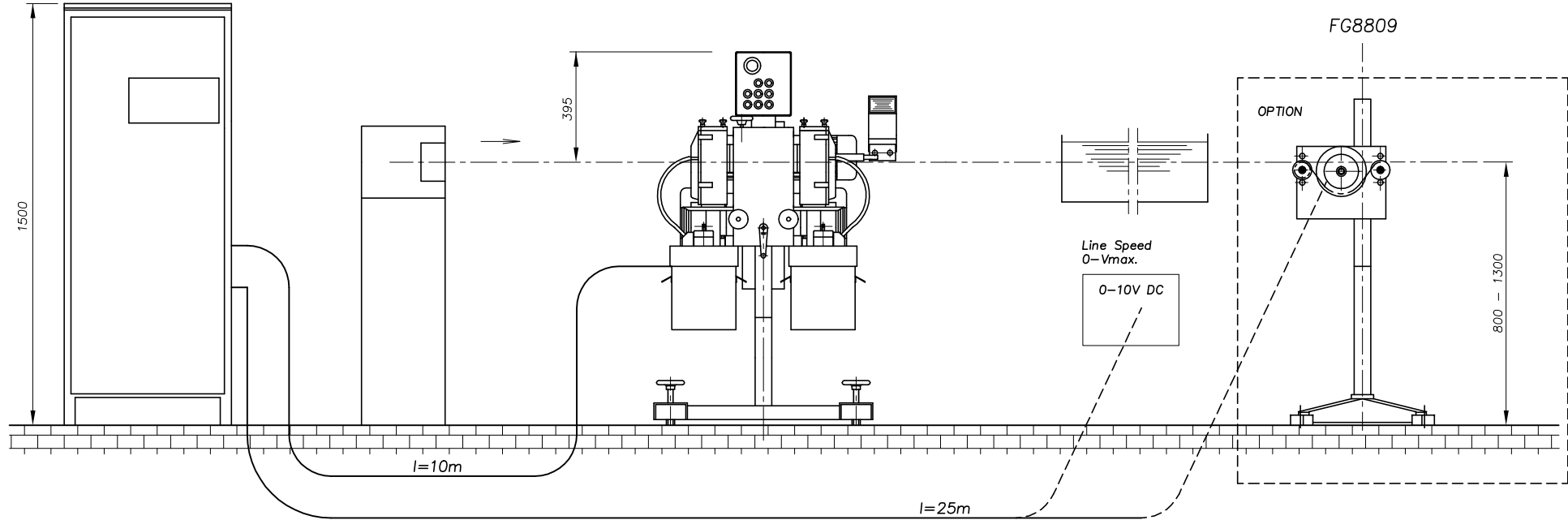

Freimasstoleranz nach ÖNORM M 1365 - Genauigkeitsgrad >FEIN 1<

Benennung
**Setting up of the complete
Ring Marking Equipment
Model 2xRS70**

MEDEK & SCHÖRNER
Gesellschaft m. b. H.
Präzisionsmechanik-Maschinenbau-Elektronik
A - 1142 Wien Kuefsteingasse 32 Austria

gezeichnet	'94-06-15 <i>Hg</i>	Gerät	Z. Nr.
Cueltigkeit		2xRS70	AZ Nr. 1017